



0-775-00 - 7" 1080p AHD Mirror Monitor Camera System

Durite 7" 1080p AHD Mirror Monitor Camera system. Sony 1/2.8" AHD CMOS IMX307, IP68 with microphone. Supplied with 20M extension cable and remote. UKCA, CE. E Marked R10 EMC.

THE TRUSTED QUALITY BRAND FOR PROFESSIONALS



WARNINGS

Before using this unit please read these instructions carefully. Take special care to follow the warnings and safety suggestions listed below. Keep these instructions for future reference. There are no user-serviceable parts within the unit, refer servicing to qualified service personnel.

PRECAUTIONS

- Please ensure you are familiar and comply with local traffic and driving regulations.
- Connection - The camera should only be connected to a Durite CCTV system.
- Heat - Do not install the camera near heat sources.
- Mounting - Ensure the camera is facing the desired direction before fixing the camera base. If fixing to isolated return chassis the camera bracket should be isolated from the vehicle chassis.
- Service - The user should not attempt to service these units beyond that described in these instructions. All other servicing should be referred to an authorised service technician.

GENERAL

The camera has a CMOS image sensor which gives a high quality picture and its solid state circuitry provides extremely long life. Compact size and single connection make it easy to install. Automatic gain control (AGC) provides a clear image in both strong sunlight and low light conditions. It is recommended that all camera lead connections are additionally sealed by either wrapping with a suitable tape or application of heat shrink sleeving. It is recommended to connect the system and test before fixing to ensure the correct field of view is displayed.

MIRROR vs. NORMAL IMAGE

The camera default image is NORMAL image.

There is a 'jumper' included with the camera.

If MIRROR image viewing is required please connect the jumper to the applicable connection on the camera flying lead.

Disconnect then reconnect the power to the camera for the setting change to take place.

OPERATION

REMOTE CONTROL

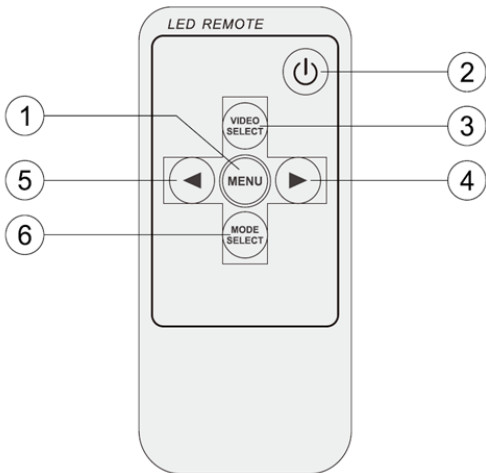

1. Menu
2. Power on
3. Video selection
4. Down selection
5. Up selection
6. Mode selection

MENU OPERATION

Press "M" button, the screen will show "Display / Guide line / System setting / Volume "menu", Press "V1/V2" button to select up and down ,press "▲ / ▼" button to increase or decrease the parameter setting .



Display: Brightness / Contrast / Saturation / Reset

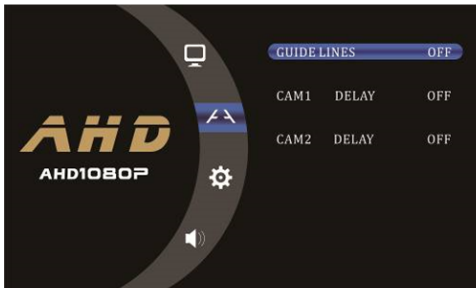

Reverse guideline: ON / OFF to select the reverse guideline, default OFF

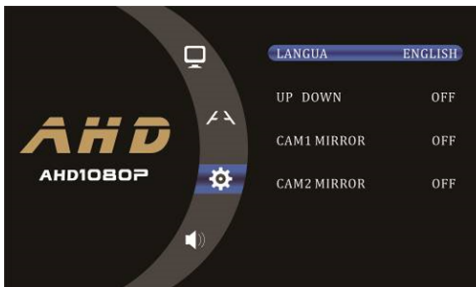

System setting: Language (English default), UP DOWN for display picture up and down change, CAM1 MIRROR and CAM2 MIRROR for Video1 and Video2 image mirrored and non-mirror display

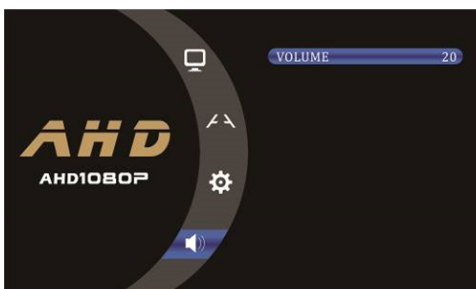

Volume: press "▲ / ▼" button to increase and decrease the parameter setting

TECHNICAL SPECIFICATIONS - Monitor

Display Device	7" Colour TFT LCD
Interface	Digital TTL
Luminance (Nits)	500
System	PAL / NTSC (auto)
Video signal format type	CVBS / AHD
P/N system resolution	1024 x RGB x 700
Video frame	60FPS
Contrast Ratio	500:1
Power Consumption	5W Max
Power Supply	10-30V
View Angle (LR/UD)	L 60, R 60, U 40, D 60 (Degree's)
Connection	4 PIN Aviation (Please see system diagram)
Weight	0.436Kg
Vibration	10G
Operating temperature	-20°C ~ 70°C, RH95% MAX
Storage temperature	-30°C ~ 70°C, RH95% MAX
Dimensions	L 249.5 x W 40.0 x H 108.0mm
Certificates	UKCA CE E Mark R10 EMC

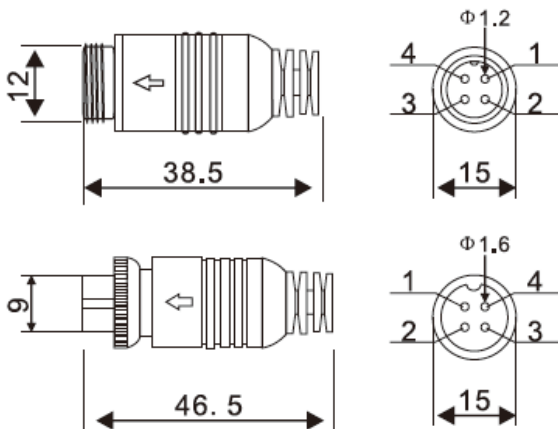
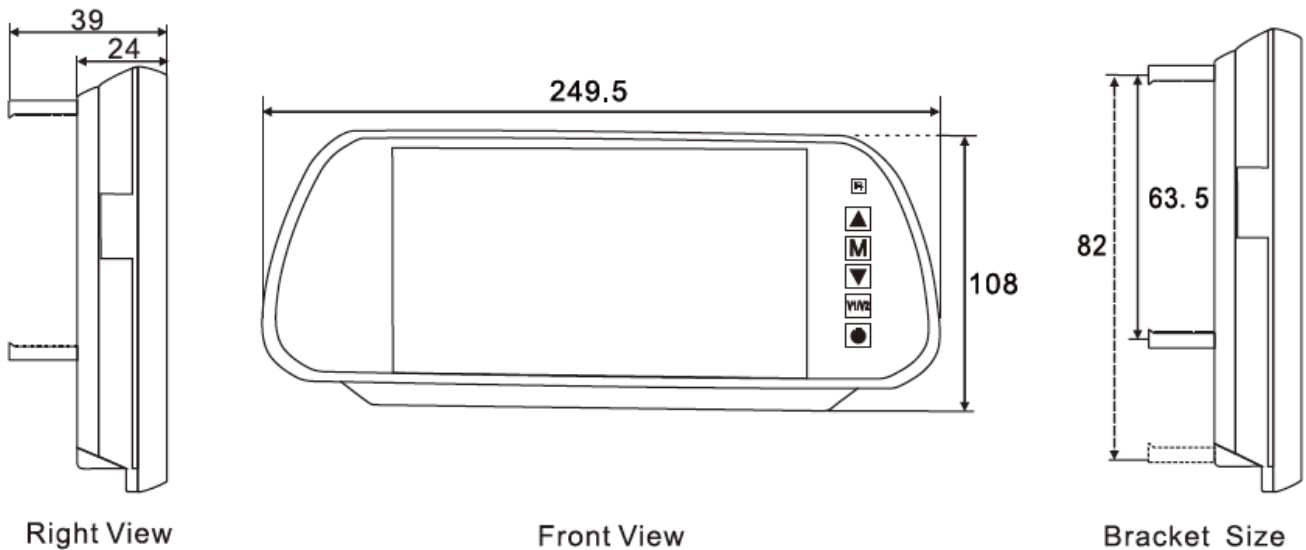

1	POWER
2	GND
3	AUDIO
4	VIDEO

TECHNICAL SPECIFICATIONS - Camera

Image sensor	1/2.8" Sony AHD1080P CMOS IMX307
Resolution	1920(H)X1080(V) pixels
Lens	2.8mm
Video Mode	60FPS
Viewing angle	120° H, 95° V
TV System	PAL
Sensitivity	0 LUX with IR on
Night vision distance	Upto 8 Metres
Image mode	Normal
Vibration	10G
IR LED light	4 LED's
Power voltage	12VDC
Audio	YES
WDR	YES
AGC	YES
Electronic Shutter	Auto
Waterproof rating	IP68
Current Draw at 12V	200mA
Camera connector type	4 PIN Aviation (Please see system diagram)
Weight	0.360Kg
Dimensions	L 84 x W 76 x H 70mm
Operating temperature	-20°C ~ 70°C, RH95% MAX
Storage temperature	-30°C ~ 75°C, RH95% MAX
Dimensions	Please see below diagram
Certificate	UKCA CE, E Marked R10 EMC

